

**ELMAK**<sup>®</sup>

ELMAK CRANE (SHANGHAI) CO.,LTD.

# **TOWER CRANE CABIN**

[www.elmaktowercrane.com](http://www.elmaktowercrane.com)

**Catalogue**

**Options**

- 1.Power distribution box.
- 2.Air-con.
- 3.Emergency light.
- 4.Fire extinguisher
- 5.Operator console.
- 6.Blinds and curtains.
- 7.Electric wiper & washer.
- 8.Interior walls are decorated with imitation leather.
- 9.Interior walls are decorated with steel sheet .

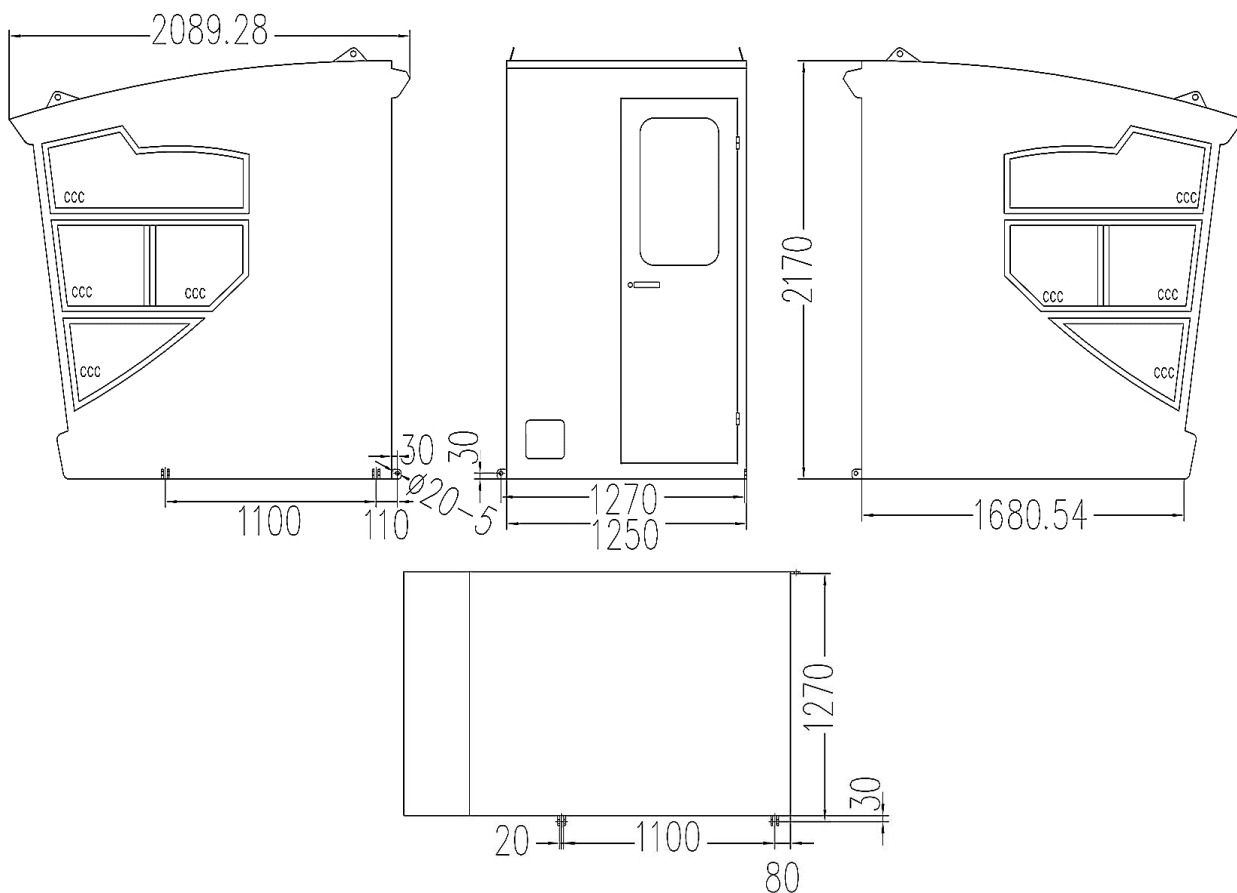
**Sizes(mm)**
**Cabin Model: EQST9**

## Characters

- 1.Externail covering is constructed with fine steel plates.
- 2.Tubes,plate and channels are bent and welded to be cabin frame.
- 3.Interior walls decorated with poly board.
- 4.Tempered glass.

## Standard Design

- 1.Ceiling light .
- 2.Outlets and sockets.
- 3.Fan.
- 4.Windshield wiper



**Cabin Model: EQST8**

## Sizes(mm)

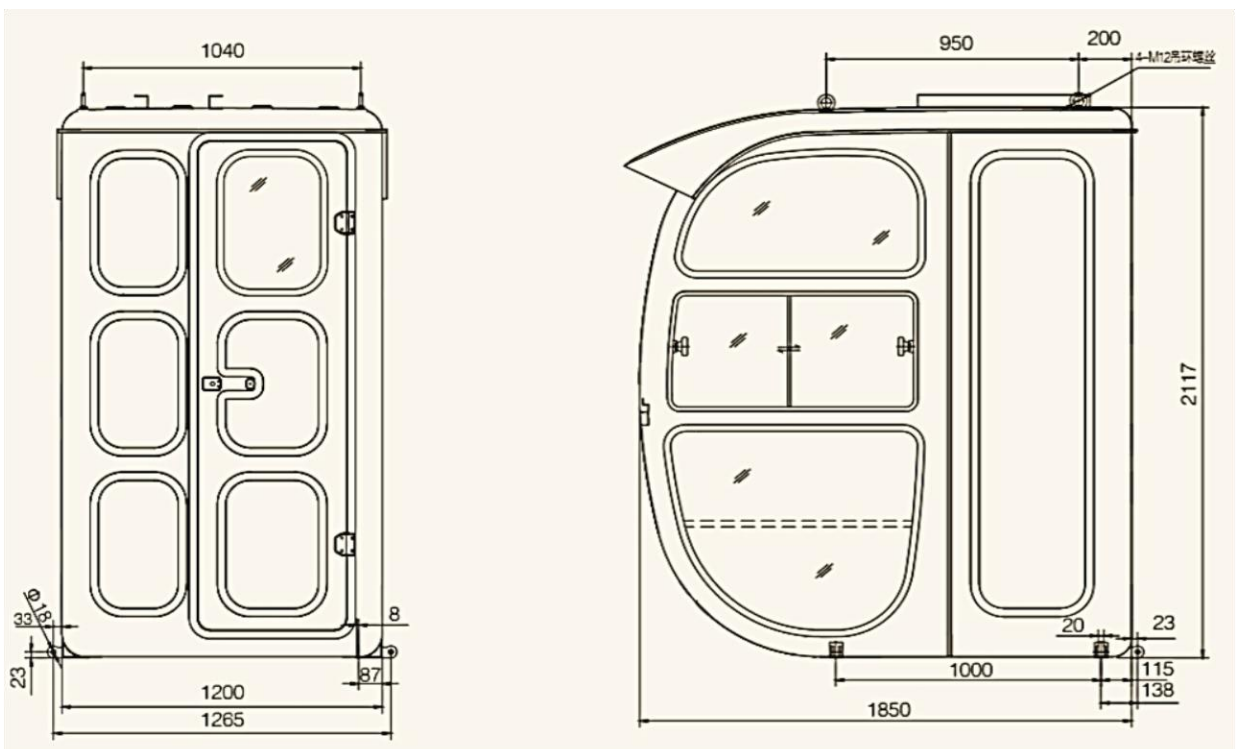

**Options**

- 1.Power distribution box.
- 2.Air-con.
- 3.Emergency light.
- 4.Fire extinguisher
- 5.Operator console.
- 6.Blinds and curtains.
- 7.Electric wiper & washer.
- 8.Interior walls are decorated with imitation leather.
- 9.Interior walls are decorated with steel sheet .

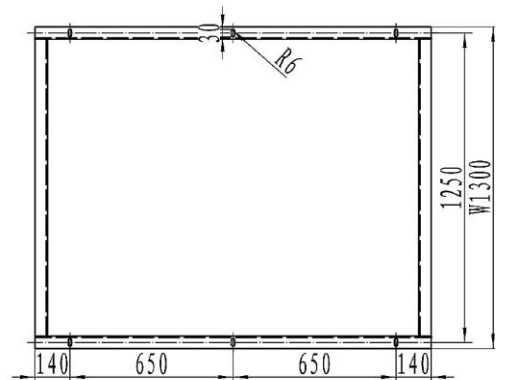
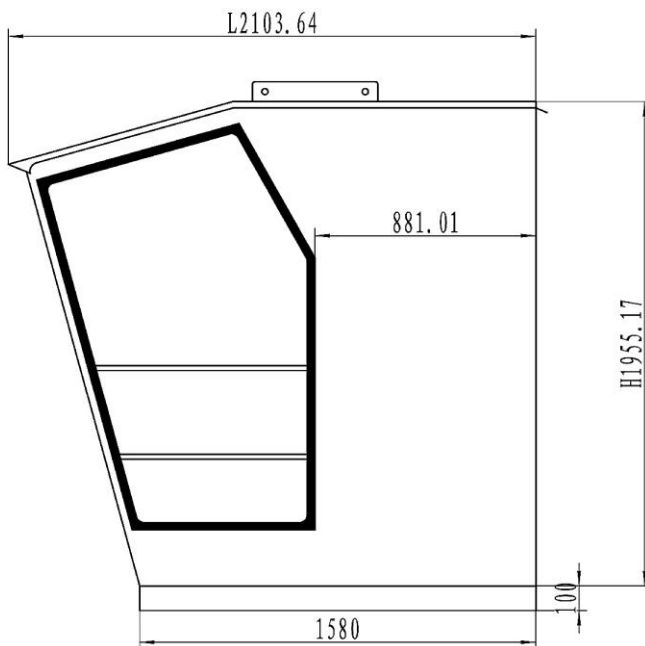
**Cabin Model: EQST10**
**Sizes(mm)**

**Options**

- 1.Power distribution box.
- 2.Air-con.
- 3.Emergency light.
- 4.Fire extinguisher
- 5.Operator console.
- 6.Blinds and curtains.
- 7.Electric wiper & washer.
- 8.Interior walls are decorated with imitation leather.
- 9.Interior walls are decorated with steel sheet .

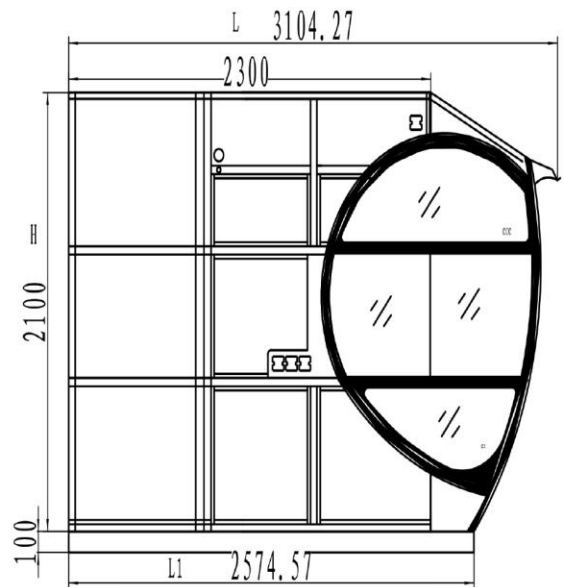
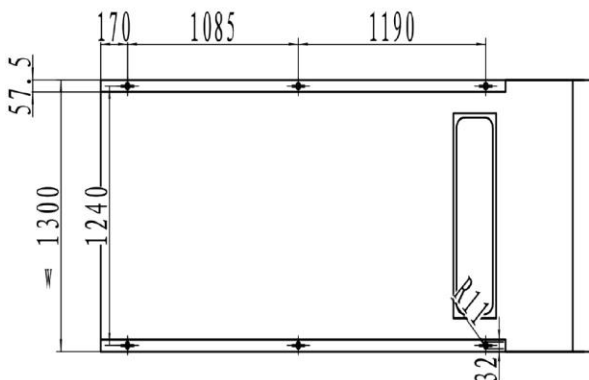
**Cabin Model: EQST11**
**Sizes(mm)**

**Options**

- 1.Power distribution box.
- 2.Air-con.
- 3.Emergency light.
- 4.Fire extinguisher
- 5.Operator console.
- 6.Blinds and curtains.
- 7.Electric wiper & washer.
- 8.Interior walls are decorated with imitation leather.
- 9.Interior walls are decorated with steel sheet .

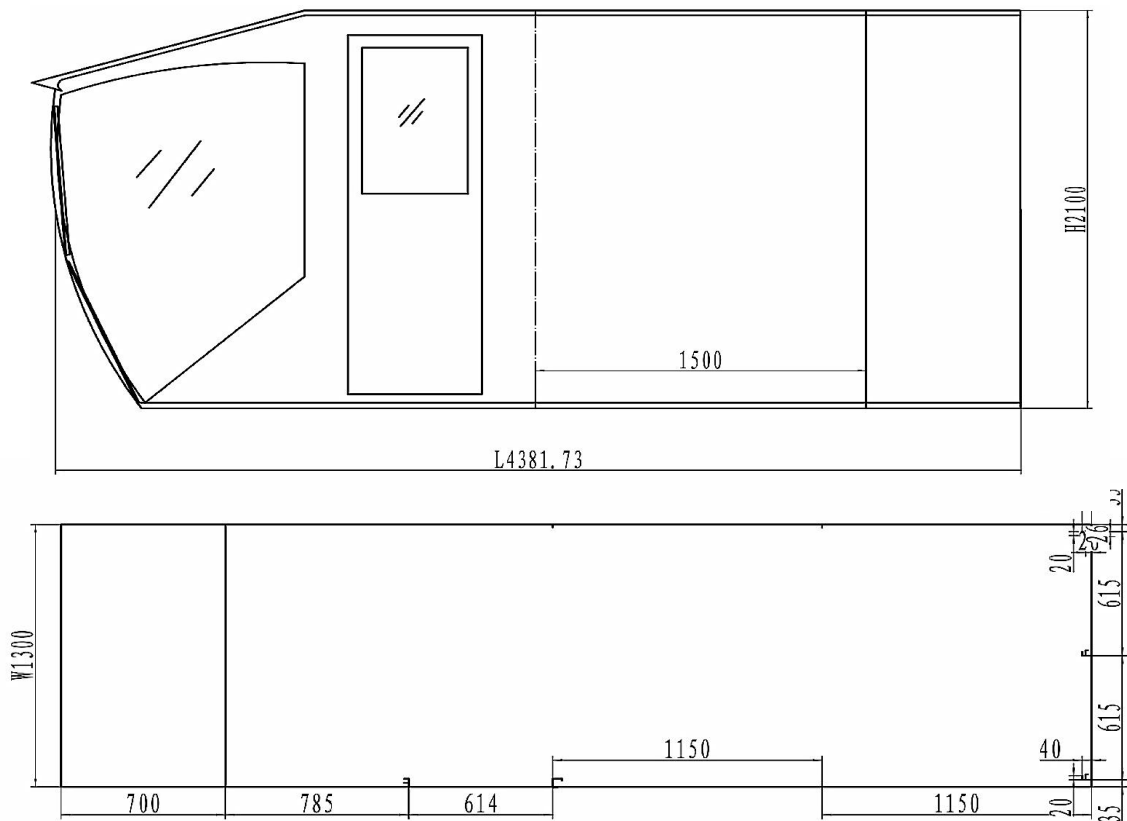
**Cabin Model: EQST12**
**Sizes(mm)**

**Options**

- 1.Power distribution box.
- 2.Air-con.
- 3.Emergency light.
- 4.Fire extinguisher
- 5.Operator console.
- 6.Blinds and curtains.
- 7.Electric wiper & washer.
- 8.Interior walls are decorated with imitation leather.
- 9.Interior walls are decorated with steel sheet .

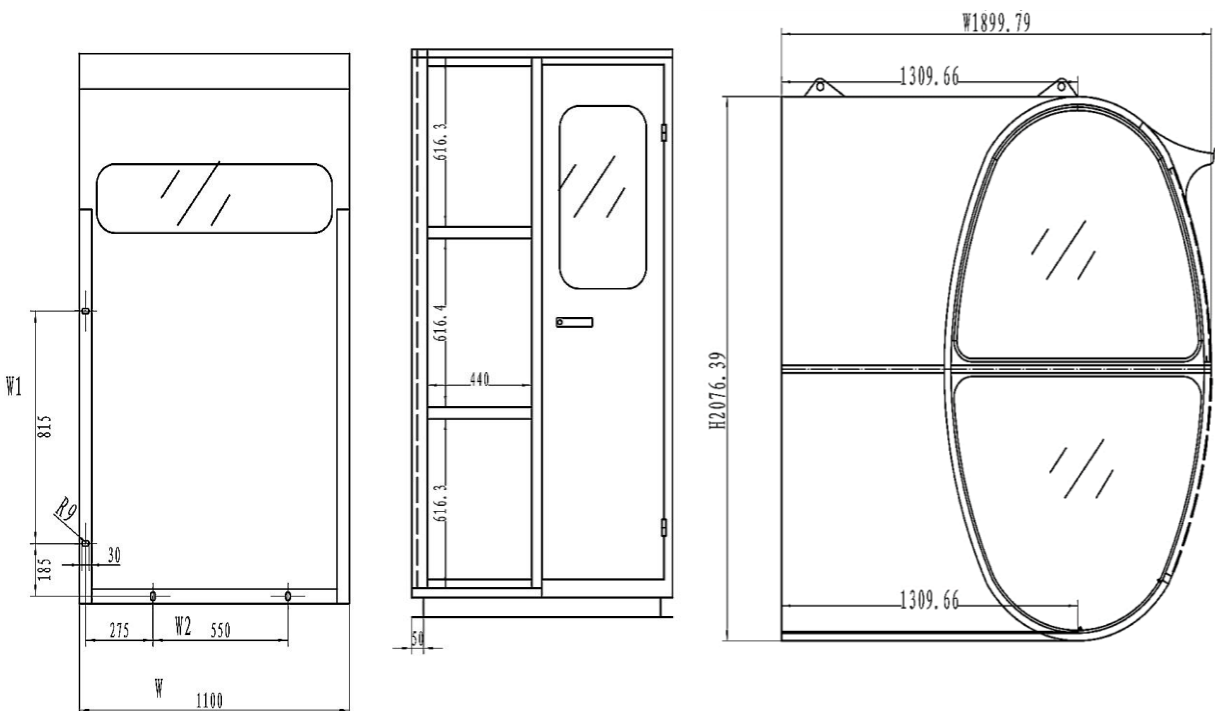
**Cabin Model: EQST13**
**Sizes(mm)**

**Options**

- 1.Power distribution box.
- 2.Air-con.
- 3.Emergency light.
- 4.Fire extinguisher
- 5.Operator console.
- 6.Blinds and curtains.
- 7.Electric wiper & washer.
- 8.Interior walls are decorated with imitation leather.
- 9.Interior walls are decorated with steel sheet .

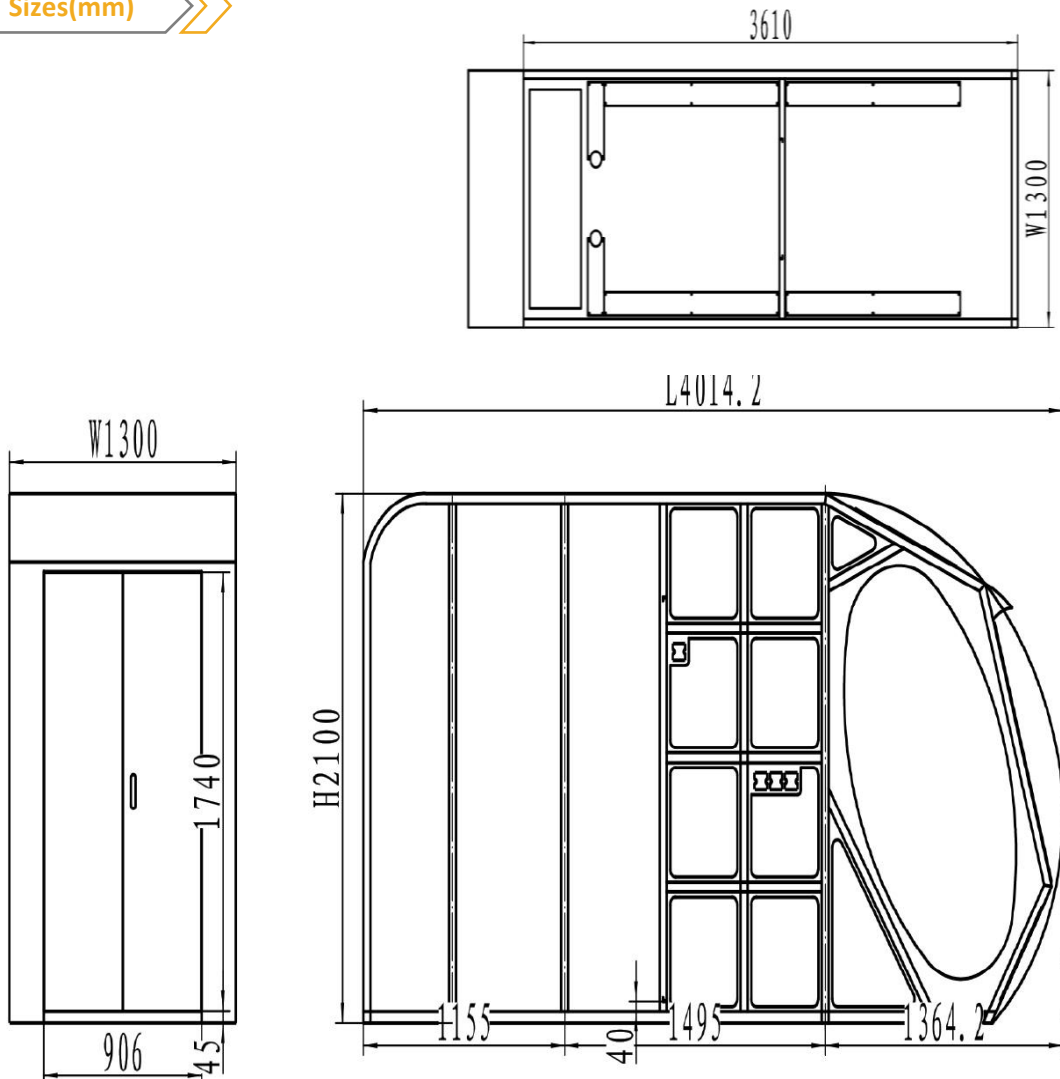
**Cabin Model: EQST14**
**Sizes(mm)**



**Options**

- 1.Power distribution box.
- 2.Air-con.
- 3.Emergency light.
- 4.Fire extinguisher
- 5.Operator console.
- 6.Blinds and curtains.
- 7.Electric wiper & washer.
- 8.Interior walls are decorated with imitation leather.
- 9.Interior walls are decorated with steel sheet .

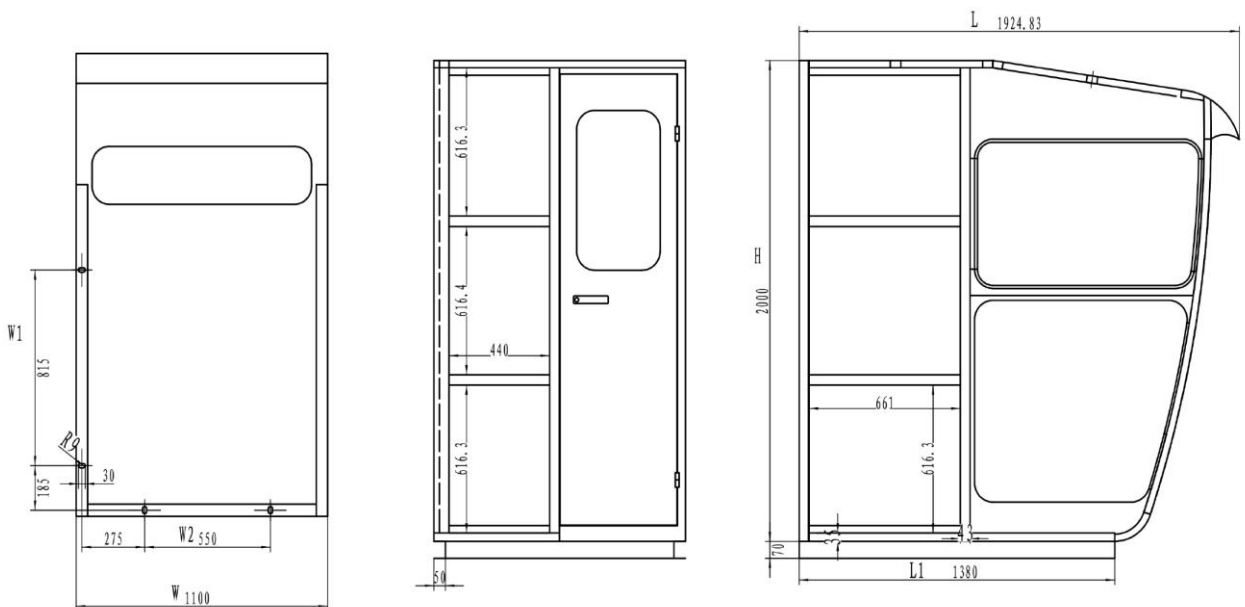

**Cabin Model: EQST15**
**Sizes(mm)**

**Options**

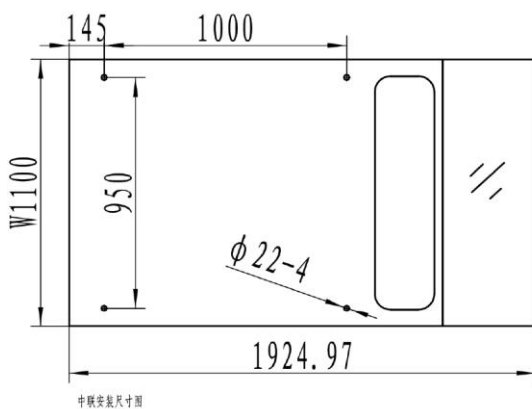
- 1.Power distribution box.
- 2.Air-con.
- 3.Emergency light.
- 4.Fire extinguisher
- 5.Operator console.
- 6.Blinds and curtains.
- 7.Electric wiper & washer.
- 8.Interior walls are decorated with imitation leather.
- 9.Interior walls are decorated with steel sheet .

**Cabin Model: EQST16**
**Sizes(mm)**

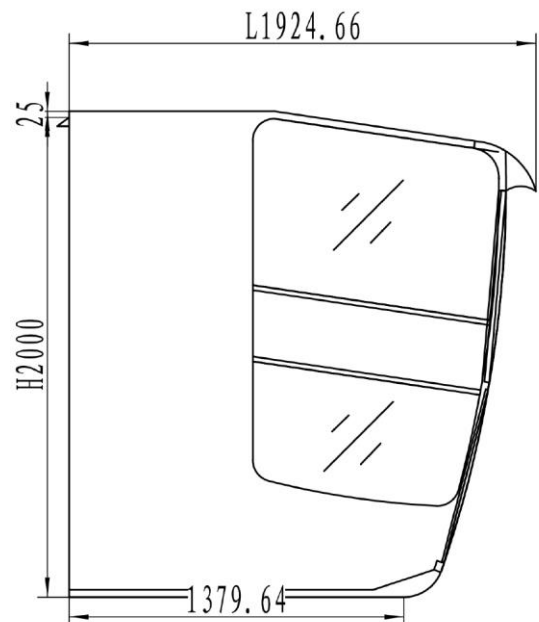
中联安机尺寸图



**All cabin sizes  
can be customized.**

The electrical appliances in the power distribution cabinet can use the famous Schneider inverters or Japan Yaskawa inverters.



**Cabin Sizes(m)**

L*W*H	1.8*1.3*2.0
1.51.1*2.0	2*1.25*2.20
1.7*1.1*2.0	3.5*1.3*2.20
1.7*1.2*2.0	4.2*1.3*2.20



## Technical Parameters

Size L1 or L2	75	88	101	114	127
Number of contact layers	1	2	3	4	5

Handle gear	1-0-1	2-0-2	3-0-3	4-0-4	5-0-5
Handle angle	1	2	3	4	5

Handle form	A	B	C	D	E
H(mm)	189	143	195	154	150



## Drawings

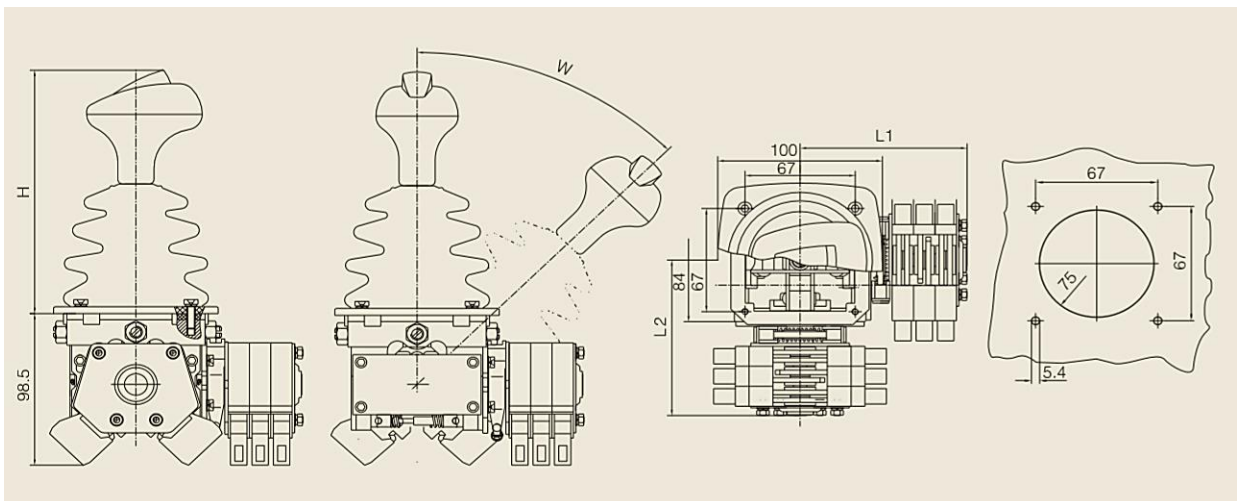

## Technical Parameters

H(mm)	69.5	99.5
Contact Number	1~4	5~8



## Drawings

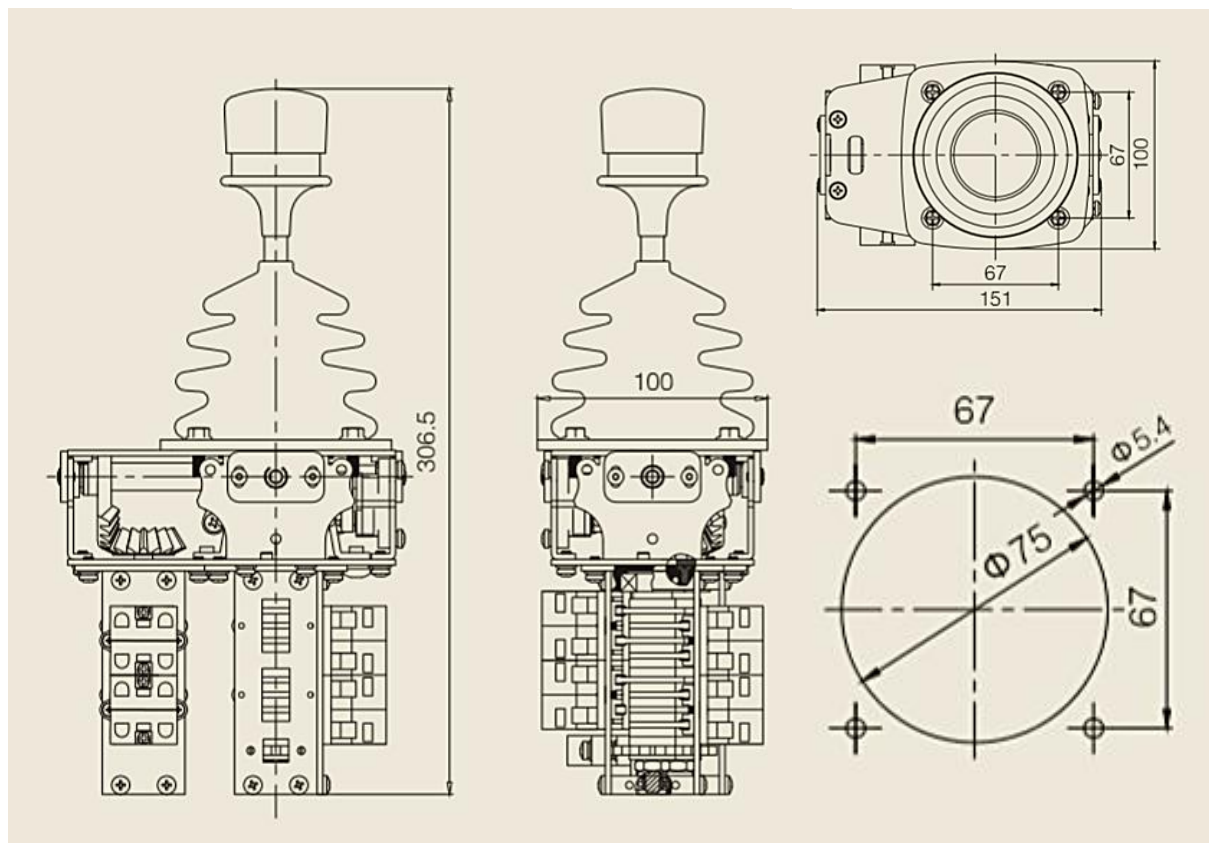

## Model and implication



## Structure characteristic

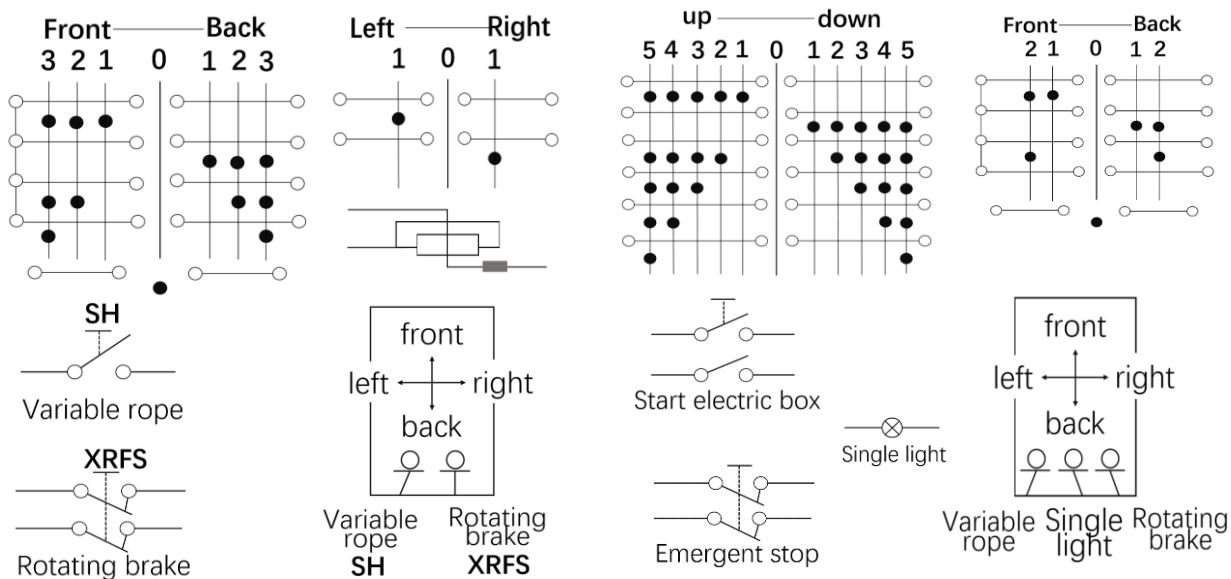

## Technical parameter

Rated working voltage	380V	Handle operating force	No more than 25 N
Rated working current	2.5A	Rated operating frequency	600/H
Application classification	AC-15	Maximum control gear number	5
Appointed heater current	10A	Machanical life	3 million
Appointed insulation voltage	660V	Electric life	1 million

Model:A

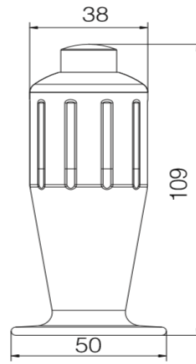
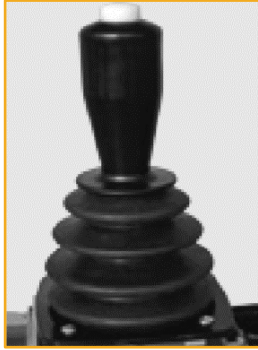

Model:B

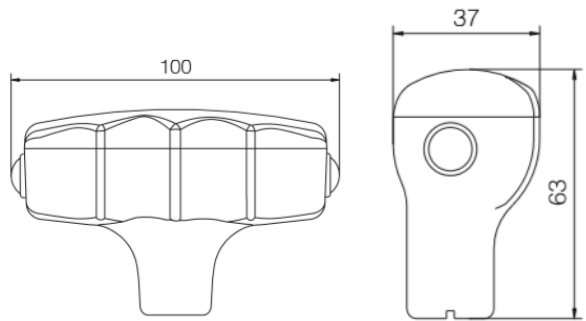
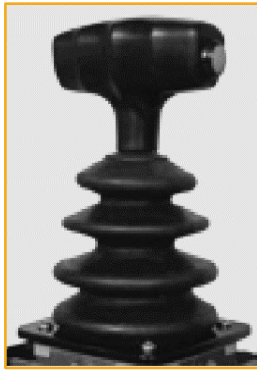

Model:C

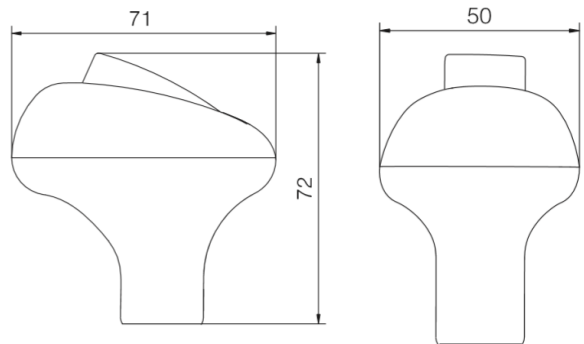

Model:D

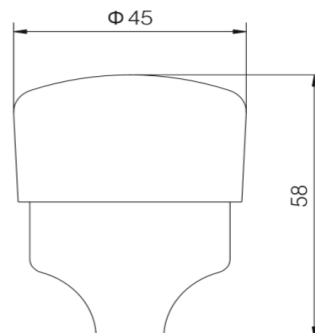

**Application**

EQTA8 crane console is mainly used in AC 50Hz (60Hz) rated voltage 380V (440V) and below control circuits to control the starting, speed regulation, braking and reversing of motors of lifting and transportation machinery.

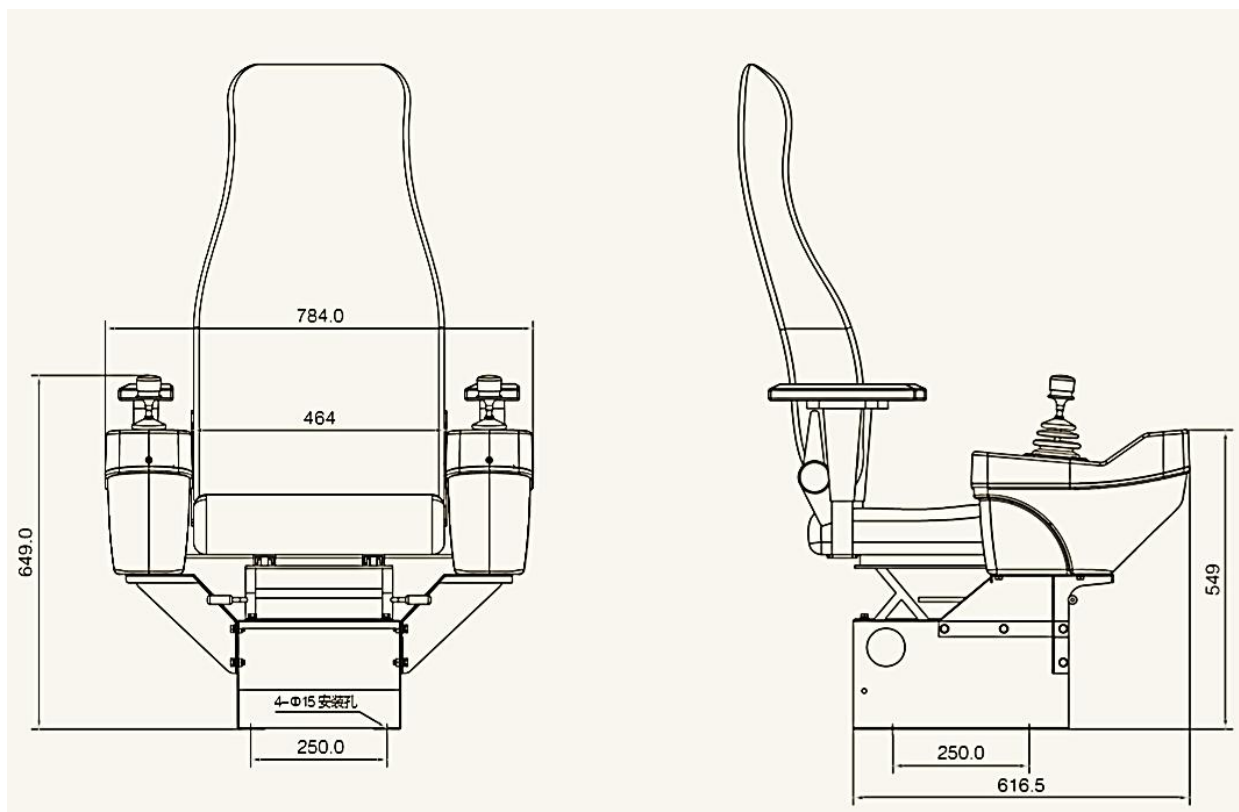
**Driver seat Model: EQTA8****Size(mm)**

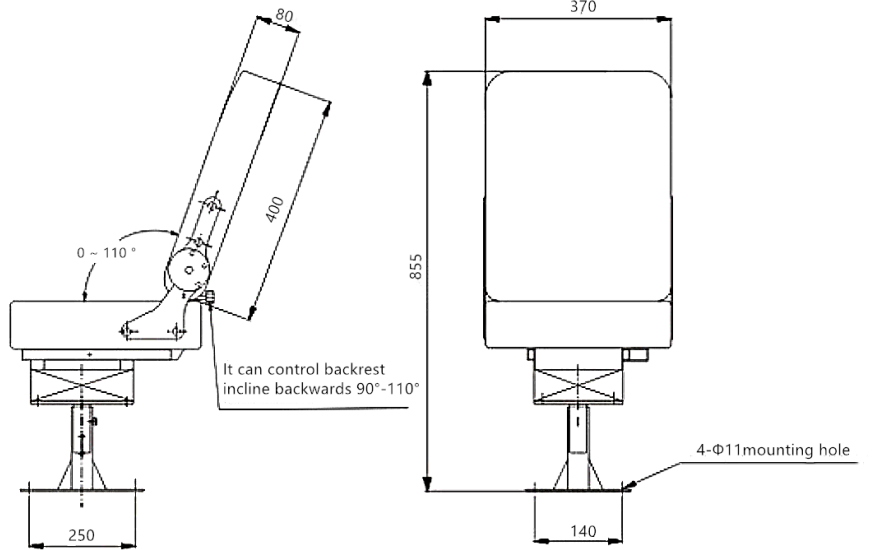
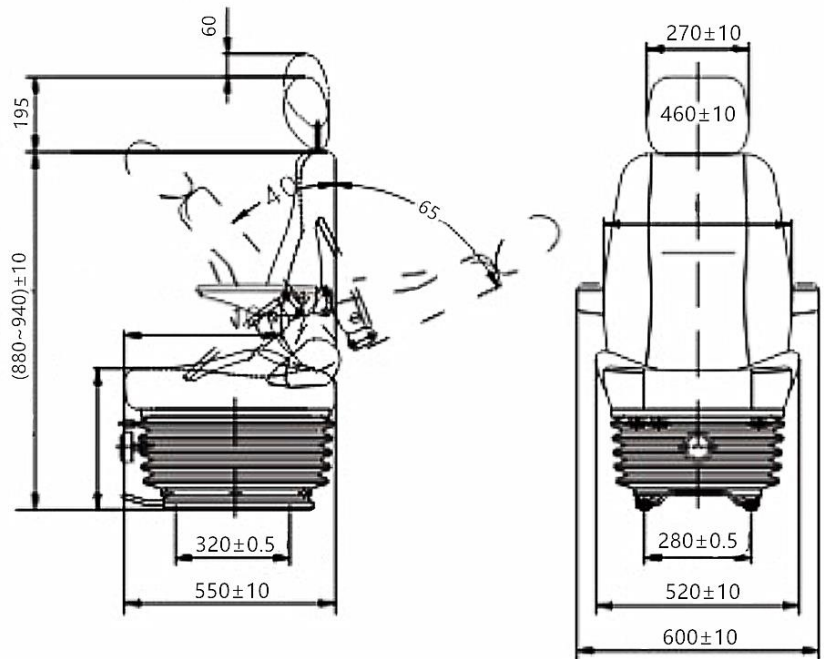

**EZY02**

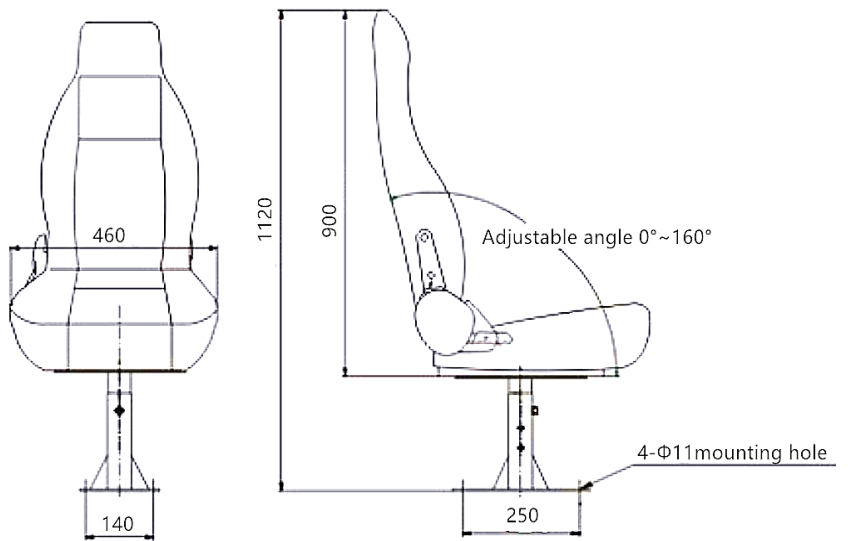
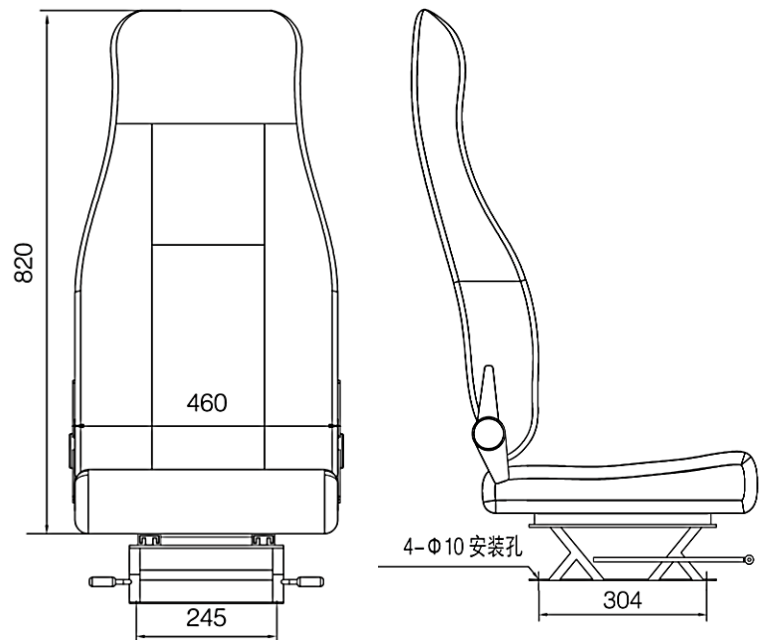
**EZY05**

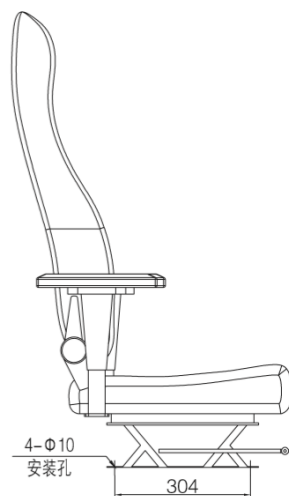
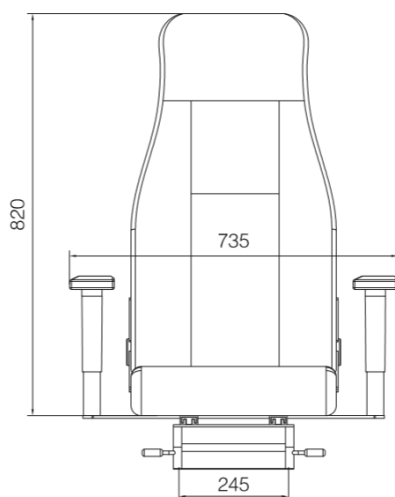
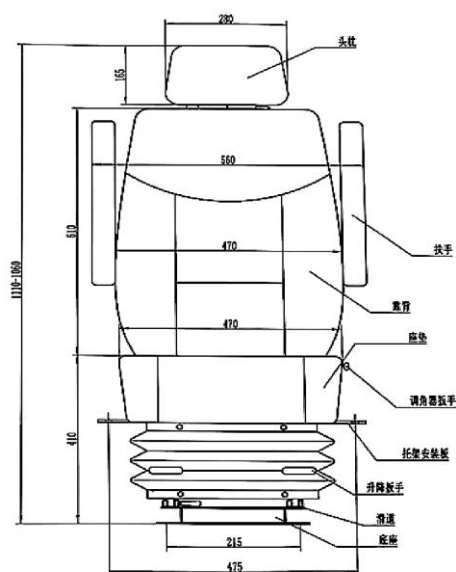
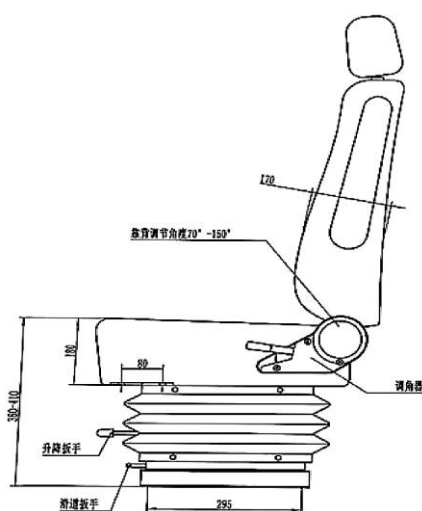
**EZY08**

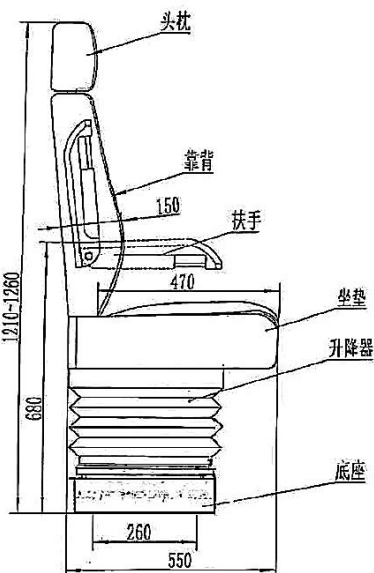
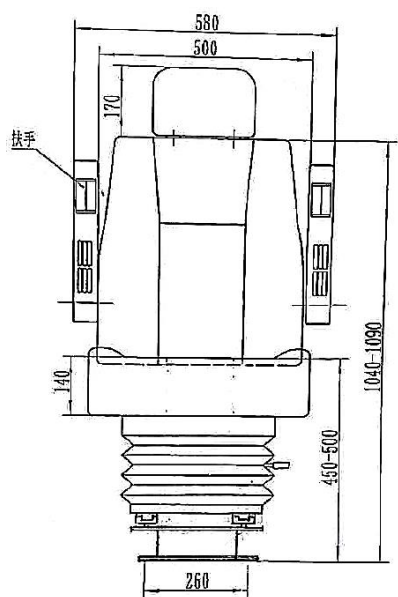
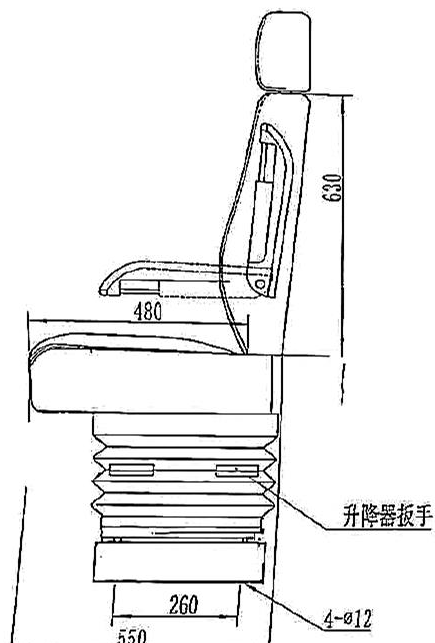
**EZY08-B2**

**EZY08-A3B2**

**EZY10**

**EZY11**

**ELMAK OFFICE:**
**ELMAK CRANE (SHANGHAI) CO.,LTD.**

ADD:Room 901, Building No:1,100

Jinyu Road Shanghai,CHINA,201206.

Tel: +86 18376695766/+86 18616934760

+66 830392867

E-mail:

xiaoli@elmaktowercrane.com

Lucy\_tu@elmaktowercrane.com

**ELMAK FACTORY:**
**ELMAK CRANE SHANDONG CO.,LTD.**

ADD:No.1 OF Chijin Road,Gejia Town,

Wendeng District, Weihai City,

Shandong Province,China, 264422.

Tel:+86 18018311520

E-mail:marvin@elmaktowercrane.com